



**Maximum Ratings**

Supply Voltage  $V_{CC}$  ..... -0.5 V to +6.0 Vdc  
 Voltage, Any Pin Respect to GND . -0.5 to ( $V_{CC} + 0.5$ ) Vdc  
 Operating Temperature ..... -40°C to +85°C  
 Storage Temperature ..... -40°C to +100°C  
 Maximum Solder Temperature, 1.59 mm (0.063")  
 below Seating Plane,  $t < 5$  sec ..... 260°C  
 Relative Humidity (non condensing) @85°C ..... 85%

**Optical Characteristics**

Time Averaged Luminous Intensity  
 per digit (8 segments) ..... 0.25 mcd min.  
 @25°C ..... 0.75 mcd typ.  
 Off Axis Viewing Angle.  
 Horizontal .....  $\pm 30^\circ$   
 Vertical .....  $\pm 50^\circ$   
 Digit size ..... 0.160" x 0.125"  
 Spectral Peak Wavelength ..... 660 nm  
 LED to LED Intensity Matching ..... 1.8:1.0 max.  
 Average Display Intensity Matching (one bin) . 1.5:1.0 max.  
 Bin to Bin Intensity Matching (adjacent bins) . 1.9:1.0 max.

**TIMING CHARACTERISTICS**

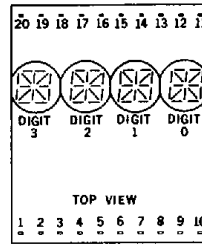
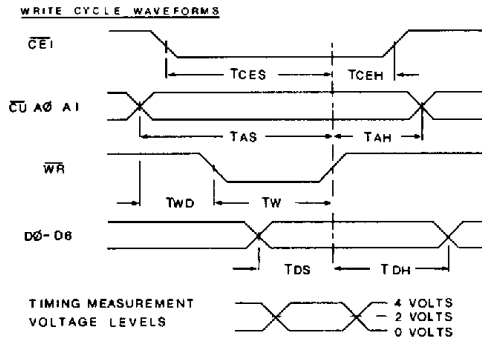

| Pin | Function        | Pin | Function        |
|-----|-----------------|-----|-----------------|
| 1   | D5 Data Input   | 11  | A1 Digit Select |
| 2   | D4 Data Input   | 12  | Unused          |
| 3   | D0 Data Input   | 13  | Unused          |
| 4   | D1 Data Input   | 14  | Unused          |
| 5   | D2 Data Input   | 15  | Unused          |
| 6   | D3 Data Input   | 16  | Unused          |
| 7   | CE Chip Enable  | 17  | Unused          |
| 8   | WR Write        | 18  | V+              |
| 9   | CU Cursor Input | 19  | V-              |
| 10  | A0 Digit Select | 20  | D6 Data Input   |

**DC CHARACTERISTICS**

| Parameter                              | -40°C |      |      | +25°C |      |      | +85°C |      |      | Units   | Conditions                                   |
|----------------------------------------|-------|------|------|-------|------|------|-------|------|------|---------|----------------------------------------------|
|                                        | Min.  | Typ. | Max. | Min.  | Typ. | Max. | Min.  | Typ. | Max. |         |                                              |
| $I_{CC}$ 4 Digits on 10 segments/digit |       | 115  | 140  |       | 80   | 125  |       | 65   | 100  | mA      | $V_{CC} = 5$ V                               |
| $I_{CC}$ Blank                         |       | 2.5  | 4.0  |       | 2.0  | 3.5  |       | 1.5  | 2.5  | mA      | $V_{CC} = \overline{WR} = 5$ V, $BL = 0.8$ V |
| $I_{IL}$                               |       | 100  | 120  |       | 75   | 90   |       | 60   | 75   | $\mu$ A | $V_{CC} = 5$ V, $V_{IN} = 0.8$ V             |
| $V_{IH}$                               | 2.0   |      |      | 2.0   |      |      | 2.0   |      |      | V       | $V_{CC} = 5 \pm 0.5$ V                       |
| $V_{IL}$                               |       |      | 0.8  |       |      | 0.8  |       |      | 0.8  | V       | $V_{CC} = 5 \pm 0.5$ V                       |

**AC CHARACTERISTICS** Minimum at  $V_{CC} = 4.5$  V in nanoseconds

| Parameter               | Symbol    | -40°C | +25°C | +85°C |
|-------------------------|-----------|-------|-------|-------|
| Address Set Up Time     | $T_{AS}$  | 225   | 300   | 400   |
| Cursor Set Up Time      | $T_{CUS}$ | 225   | 300   | 400   |
| Chip Enable Set Up Time | $T_{CES}$ | 225   | 300   | 400   |
| Data Set Up Time        | $T_{DS}$  | 100   | 175   | 300   |
| Write Time              | $T_W$     | 150   | 250   | 350   |
| Address Hold Time       | $T_{AH}$  | 30    | 50    | 80    |
| Data Hold Time          | $T_{DH}$  | 30    | 50    | 80    |
| Write Delay Time        | $T_{WD}$  | 30    | 50    | 80    |
| Chip Enable Hold        | $T_{CEH}$ | 30    | 50    | 80    |
| Cursor Hold Time        | $T_{CUH}$ | 30    | 50    | 80    |
| Access Time             | $T_{ACC}$ | 255   | 350   | 480   |

**LOADING DATA**

The chip enable ( $\overline{CE}$ ) held low and cursor ( $\overline{CU}$ ) held high will enable data loading. The desired data code ( $D_0-D_6$ ) and selected digit address ( $A_0-A_1$ ) should be held stable while write ( $\overline{W}$ ) is low for storing new data. The timing parameters in the AC characteristics table are minimum and should be observed. There are no maximum timing requirements. Data entry may be asynchronous and in random order. All undefined data codes (see character set) loaded as data will display a blank.

Digit 0 is defined as the right hand digit with  $A_1 = A_0 = 0 = (\text{low})$ .

**LOADING CURSOR**

The chip enable ( $\overline{CE}$ ) and Cursor ( $\overline{CU}$ ) are held low. A write ( $\overline{W}$ ) signal will now load a cursor into any digit position addressed by ( $A_0 - A_1$ ); as defined in data entry. A cursor will be stored if  $D_0 = H$  and removed if  $D_0 = L$ . The ( $\overline{CU}$ ) pulse width should not be less than write ( $\overline{WR}$ ) pulse or erroneous data may appear in the display.

TYPICAL LOADING DATA STATE TABLE

| CONTROL         |                 |                | ADDRESS |       | DATA INPUT |       |       |       |       |       |       |                   | DIGIT     |           |           |  |
|-----------------|-----------------|----------------|---------|-------|------------|-------|-------|-------|-------|-------|-------|-------------------|-----------|-----------|-----------|--|
| $\overline{CE}$ | $\overline{CU}$ | $\overline{W}$ | $A_1$   | $A_0$ | $D_6$      | $D_5$ | $D_4$ | $D_3$ | $D_2$ | $D_1$ | $D_0$ | 3                 | 2         | 1         | 0         |  |
| H               | X               | X              | X       | X     | X          | X     | X     | X     | X     | X     | X     | NO CHANGE         | NO CHANGE | NO CHANGE | NO CHANGE |  |
| L               | H               | L              | L       | L     | H          | L     | L     | L     | L     | L     | H     | NO CHANGE         | NO CHANGE | NO CHANGE | A         |  |
| L               | H               | L              | L       | H     | H          | L     | L     | L     | L     | H     | L     | NO CHANGE         | NO CHANGE | B         | A         |  |
| L               | H               | L              | H       | L     | H          | L     | L     | L     | L     | H     | H     | NO CHANGE         | C         | B         | A         |  |
| L               | H               | L              | H       | H     | H          | L     | L     | L     | L     | H     | L     | D                 | C         | B         | A         |  |
| L               | H               | L              | L       | L     | H          | L     | L     | L     | H     | L     | H     | D                 | C         | B         | E         |  |
| L               | H               | L              | L       | L     | H          | L     | L     | L     | H     | L     | H     | D                 | K         | B         | E         |  |
| L               | H               | L              | -       | -     | -          | -     | -     | -     | -     | -     | -     | SEE CHARACTER SET |           |           |           |  |

X = DON'T CARE

TYPICAL LOADING CURSOR STATE TABLE

| CONTROL         |                 |                 | ADDRESS |       | DATA  |       |       |       |       |       |       |                                   | DISPLAY DIGIT |   |   |  |
|-----------------|-----------------|-----------------|---------|-------|-------|-------|-------|-------|-------|-------|-------|-----------------------------------|---------------|---|---|--|
| $\overline{CE}$ | $\overline{CU}$ | $\overline{WR}$ | $A_1$   | $A_0$ | $D_6$ | $D_5$ | $D_4$ | $D_3$ | $D_2$ | $D_1$ | $D_0$ | 3                                 | 2             | 1 | 0 |  |
| X               | X               | H               | X       | X     | X     | X     | X     | X     | X     | X     | X     | PREVIOUSLY LOADED DISPLAY         |               |   |   |  |
| X               | X               | H               | X       | X     | X     | X     | X     | X     | X     | X     | X     | DISPLAY PREVIOUSLY STORED CURSORS |               |   |   |  |
| L               | L               | L               | L       | L     | X     | X     | X     | X     | X     | X     | H     | B                                 | E             | A | R |  |
| L               | L               | L               | L       | H     | X     | X     | X     | X     | X     | X     | H     | B                                 | E             | A | R |  |
| L               | L               | L               | H       | L     | X     | X     | X     | X     | X     | X     | H     | B                                 | E             | A | R |  |
| L               | L               | L               | H       | H     | X     | X     | X     | X     | X     | X     | H     | B                                 | E             | A | R |  |
| L               | L               | L               | H       | H     | X     | X     | X     | X     | X     | X     | H     | B                                 | E             | A | R |  |
| L               | L               | L               | H       | L     | X     | X     | X     | X     | X     | X     | L     | B                                 | E             | A | R |  |

X = DON'T CARE

CHARACTER SET

| $D_0$             | L | H | L | H  | L | H | L | H |
|-------------------|---|---|---|----|---|---|---|---|
| $D_1$             | L | L | H | H  | L | L | H | H |
| $D_2$             | L | L | L | L  | L | H | H | H |
| $D_6 D_5 D_4 D_3$ |   |   |   |    |   |   |   |   |
| L H L L           | ! | " | # | \$ | % | & | ' | / |
| L H L H           | < | > | * | +  | , | - | . | / |
| L H H L           | 0 | 1 | 2 | 3  | 4 | 5 | 6 | 7 |
| L H H H           | 8 | 9 | : | ;  | < | = | > | ? |
| H L L L           | A | B | C | D  | E | F | G |   |
| H L L H           | H | I | J | K  | L | M | N | O |
| H L H L           | P | Q | R | S  | T | U | V | W |
| H L H H           | X | Y | Z | [  | \ | ] | ^ | _ |

NOTE: All undefined data codes that are loaded or occur on power-up will cause a blank display state.

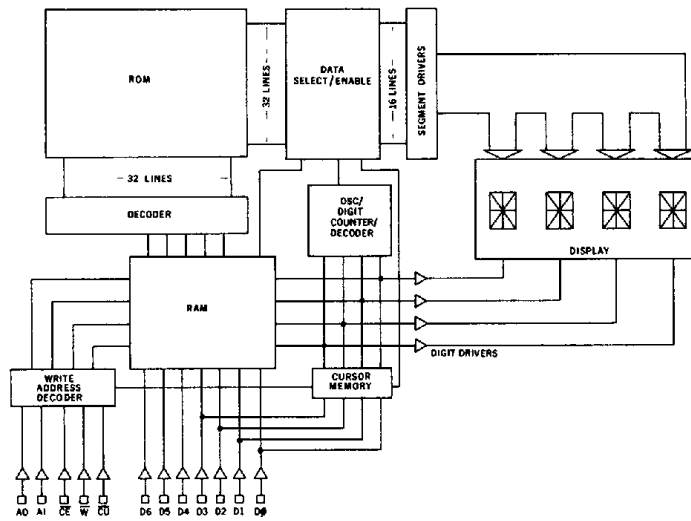

INTERNAL SCHEMATIC

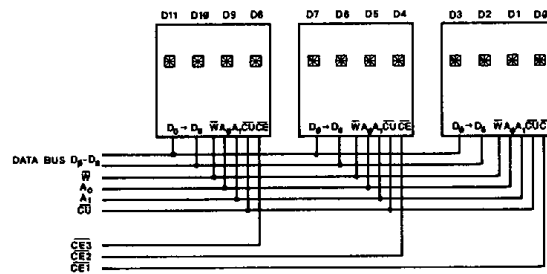

Typical interconnect for small systems. 12digits

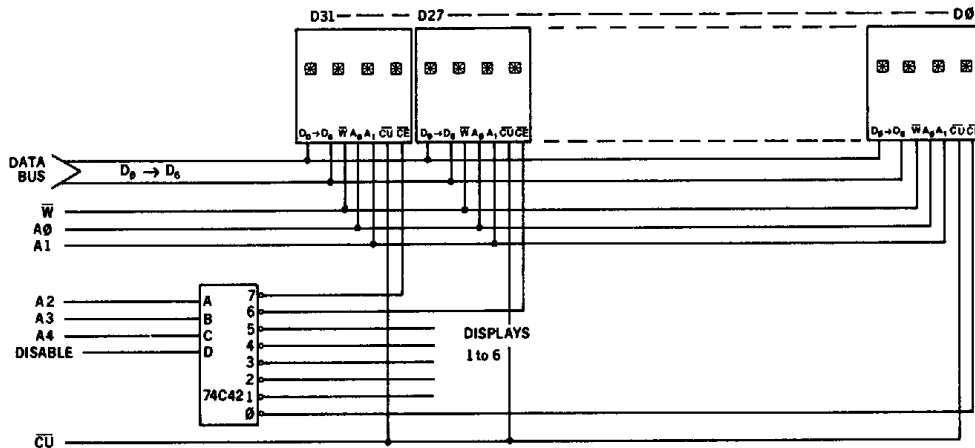

Typical schematic for 32 digit systems

**DESIGN CONSIDERATIONS**

For details on design and applications of the DL 1416B utilizing standard bus configurations in multiple display systems, or Parallel I/O devices, such as the 8255 with an 8080 or memory mapped addressing on processors such as the 8080, Z80, or 6800, or non-microprocessor based systems, please refer to Appnote 9A and 13 in our current Optoelectronic Data Book.

**ELECTRICAL AND MECHANICAL CONSIDERATIONS****VOLTAGE TRANSIENT SUPPRESSION**

It is highly recommended that the display and the components that interface with the display be powered by the same supply to avoid logic inputs higher than  $V_{CC}$ . Additionally, the LEDs may cause transients on the power supply line while they change display states. Common practice is to place .01  $\mu$ F capacitors close to the displays across  $V_{CC}$  and GND, one for each display, and one 10  $\mu$ F capacitor for every second display.

**ESD PROTECTION**

The metal gate CMOS IC of the DL 1416B is extremely immune to ESD damage. It is capable of withstanding discharges greater than 3KV. However, users of these devices are encouraged to take all the standard precautions, normal for CMOS components. These include properly grounding personnel, tools, tables, and transport carriers that come in contact with un-shielded parts. Where these conditions are not, or cannot be met, keep the leads of the device shorted together or the parts in anti-static packaging.

**SOLDERING CONSIDERATIONS**

The DL 1416B can be hand soldered with SN63 solder using a grounded iron set to 260°C.

Wave soldering is also possible following these conditions. Preheat that does not exceed 93°C on the solder side of the PC board or a package surface temperature of 85°C. Water soluble organic acid flux (except carboxylic acid) or resin-based RMA flux without alcohol can be used.

Wave temperature of 245°C  $\pm$  5°C with a dwell between 1.5 sec to 3.0 sec. Exposure to the wave should not exceed temperatures above 260°C, for 5 seconds at 0.063" below the seating plane. The packages should not be immersed in the wave.

**POST SOLDER CLEANING PROCEDURES**

The least offensive cleaning solution is hot DI water (60°C) for less than 15 minutes. Addition of mild saponifiers is acceptable. Do not use commercial dishwasher detergents.

For faster cleaning, solvents may be used. Care should be exercised in choosing these as some may chemically attack the nylon package. Maximum exposure should not exceed two minutes at elevated temperatures. Acceptable solvents are TF (trichlorotrifluoroethane), TA, 111 Trichloroethane, and unheated acetone.

Unacceptable solvents contain alcohol, methanol, methylene chloride, ethanol, TP35, TCM, TMC, TMS+, TE, and TES. Since many commercial mixtures exist, you should contact your solvent vendor for chemical composition information. Some major solvent manufacturers are Allied Chemical Corporation, Specialty Chemical Division, Morristown, NJ;

Baron-Blakeslee, Chicago, IL; Dow Chemical, Midland, MI; E I DuPont de Nemours & Co., Wilmington, DE.

Further information is available in Siemens Appnotes 18 and 19 in our current Optoelectronic Data Book.

An alternative to soldering and cleaning the display modules is to use sockets. Naturally, 20 pin DIP sockets 1.10" wide with 100" centers work well for single displays. Multiple display assemblies are best handled by longer SIP sockets or DIP sockets when available for uniform package alignment. Socket manufacturers are Aries Electronics, Inc., Frenchtown, NJ; Garry Manufacturing, New Brunswick, NJ; Robinson-Nugent, New Albany, IN; and Samtec Electronic Hardware, New Albany, IN.

Further information is available in Siemens Appnote 22 in our current Optoelectronic Data Book.

**OPTICAL CONSIDERATIONS**

The .16" high characters of the DL 1416B allow readability up to 8 feet. Proper filter selection will allow the user to build a display that can be utilized over this distance.

Filters allow the user to enhance the contrast ratio between a lit LED and the character background. This will maximize discrimination of different characters as perceived by the display user. The only limitation is cost. The cost/benefit ratio for filters can be maximized by first considering the ambient lighting environment.

Incandescent (with almost no green) or fluorescent (with almost no red) lights do not have the flat spectral response of sunlight. Plastic band-pass filters are inexpensive and effective in optimizing contrast ratios. The DL 1416B is a red display and should be matched with a long wavelength pass filter in the 600 nm to 620 nm range. For display systems of multiple colors (using other Siemens displays), neutral density grey filters offer the best compromise.

Additional contrast enhancement can be gained through shading the displays. Plastic band-pass filters with built-in louvers offer the "next step up" in contrast improvement. Plastic filters can be further improved with anti-reflective coatings to reduce glare. The trade-off is "fuzzy" characters, but mounting the filters close to the display reduces this effect. Care should be taken not to overheat the plastic filters by allowing for proper air flow.

Optimal filter enhancements for any condition can be gained through the use of circular polarized, anti-reflective, band-pass filters. The circular polarizing further enhances contrast by reducing the light that travels through the filter and reflects back off the display to less than 1%.

Several filter manufacturers supply quality filter materials. Some of them are Panelgraphic Corporation, W. Caldwell, NJ; SGL Homalite, Wilmington, DE; 3M Company, Visual Products Division, St. Paul, MN; Polaroid Corporation, Polarizer Division, Cambridge, MA; Marks Polarized Corporation, Deer Park, NY; Hoya Optics, Inc., Fremont, CA.

One last note on mounting filters: recessing display and bezel assemblies is an inexpensive way to provide a shading effect in overhead lighting situations. Several Bezel manufacturers are R M F Products, Batavia, IL; Nobex Components, Griffith Plastic Corp., Burlingame, CA; Photo Chemical Products of California, Santa Monica, CA; I E E - Atlas, Van Nuys, CA.

Please refer to Siemens Appnote 23 for further information.